



User Guide

Compact Balances MCB500 & MCB2000



Contents

1 INSTALLATION	2
2 SPECIFICATIONS	6
3 DISPLAY and KEYPAD	7
4 OPERATION.....	8
5 PARAMETER SETTINGS.....	11
6 SIMPLE CALIBRATION	15
7 COMMUNICATIONS	16
8 ERROR MESSAGES.....	18
Manufacturer's Declaration of Conformity.....	19



1 INSTALLATION

- 1) Remove the balance, draft shield, top pan, AC adapter and pan support from the packaging
- 2) Remove the shipping protection screw and transit disc from the top of the balance and place the plastic top pan support on the balance. Do not use excessive force when removing and installing the screw.

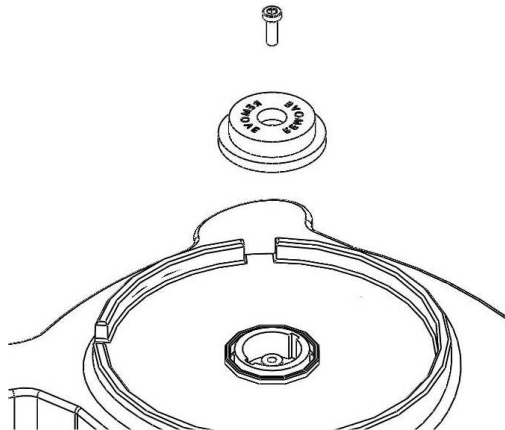

- 3) Gently place the plastic pan support into the receptacle and secure with the supplied screw. Do not over-tighten the screw. It should be finger tight only. Put the Stainless steel pan on top of the pan support
- 4) Place the draft shield on top of the balance, the location notches in the breeze shield should align with the cutouts on the balance. For optimum performance, the balance should be used with the draft shield (if provided).
- 5) Place the balance onto a firm surface and adjust it to be level using the rear feet before use.

1.1.1 LOCATING AND PROTECTING YOUR BALANCE



Avoid extremes of temperature. Do not place in direct sunlight or near air conditioning vents.



Make sure the balance is located on a strong table and free from vibration.

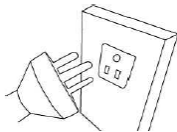

Avoid unstable power sources. Do not use near large users of electricity such as welding equipment or large motors. Do not let the balance battery go flat – if you are not using it for a long time you should charge the battery up periodically to make sure the battery does not lose its charge.

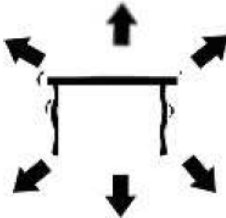

Keep free from vibration. Do not place near heavy or vibrating machinery.



Avoid high humidity that might cause condensation. Keep away from direct contact with water. Do not spray or immerse the balance in water.

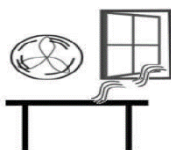

Do not place near open windows, air-conditioning vents or fans that may cause a draft and unstable readings.

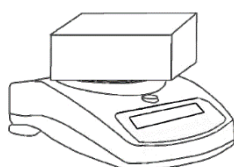

Keep the balance clean. Do not stack material on the balance / balance pan when it is not in use. The Compact balance has a stacking feature for stacking more than one unit on top of each other, which does not apply weight to the pan. For more details on this, see the section on storing

1.1.2 STORING WHEN NOT IN USE

You can store them easily on top of each other to save space and protect them from damage.

Without Shield

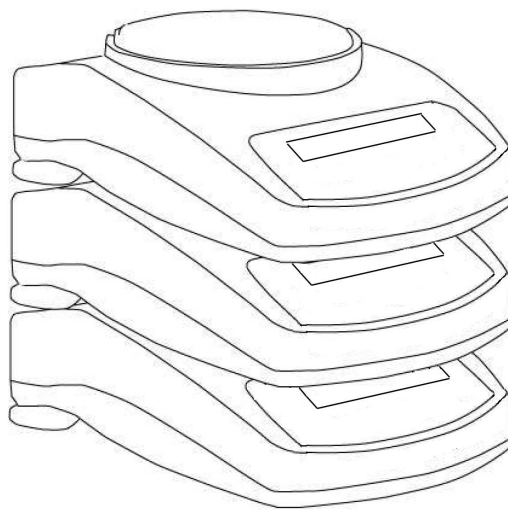

With Shield

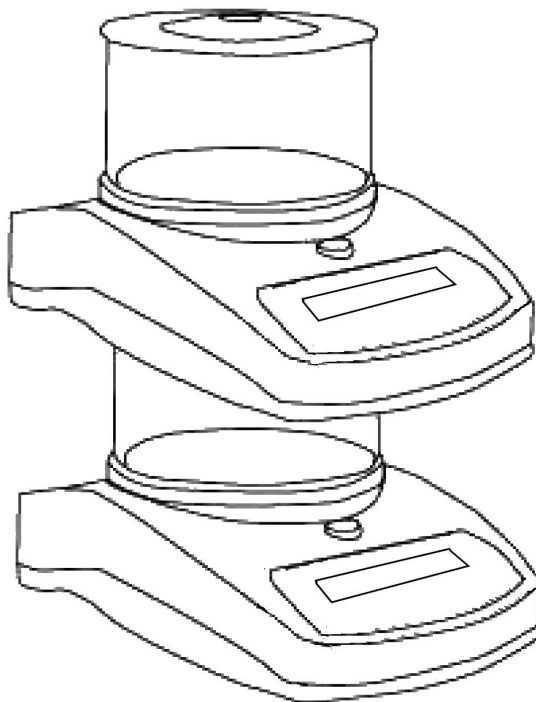



2 SPECIFICATIONS

Model	MCB500	MCB2000
Capacity	500g	2000g
Readability	0.1g	0.1g
Resolution	1:5000	1:20000
Repeatability +/-	0.1g	0.2g
Linearity+/-	0.2g	0.2g
Eccentric loading	0.2g	0.2g
Units	g / ct / GN / N / dr / Lb / oZ / oZt / tl t / tl H / tl S /CUS	

Common Specifications

Interface	RS-232 bi directional
Stabilization time	3s
Operating temperature	0°C - 40°C / 32°F - 104°F
Power supply	12VAC @ 150 ma (12VDC @ 800ma with internal battery kit option)
Calibration	Automatic external
Display	18mm 6 digits LCD
Housing	ABS
Size without breeze shield	178 x 257 x 84mm (7" x 10.1" x 3.3")
N.W.	1.1 kg (2.4 lb.)

3 DISPLAY and KEYPAD

3.1.1 Display

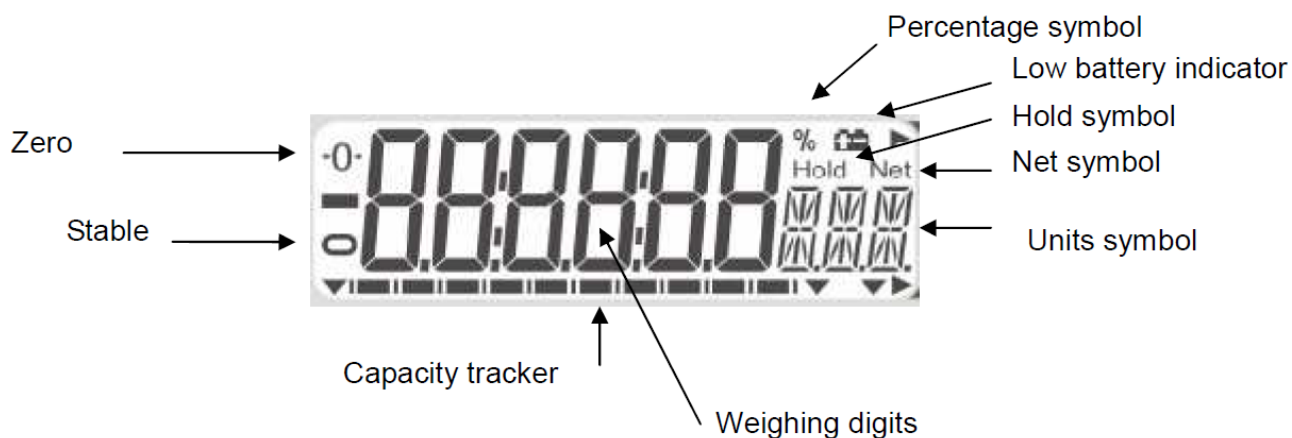

3.1.2 Keypad

KEY	FUNCTION
ON/OFF	TO POWER UP BALANCE
TARE/ZERO	TO RE ZERO OR DEDUCT WEIGHT OF EMPTY CONTAINER
SMPL (sample)	TO ENTER AND OPERATE COUNTING MODE
UNIT	TO SELECT THE REQUIRED WEIGHING UNIT
% (percent)	TO ENTER AND OPERATE PERCENTAGE WEIGHING MODE
PRINT	TO PRINT THE DISPLAYED READING WHEN CONNECTED TO A COMPUTER OR PRINTER



4 OPERATION

4.1.1 Zero/Tare

- To zero the balance, press the **[Tare/Zero]** key and the reading will show zero, the symbol “>O<” will be displayed
- Put a container on the pan and the display will show its weight.
- Press **[Tare/Zero]** to tare the weight of the container from the balance, the display will now show zero and also display the zero and NET symbol.
- Put a sample into the container and the display will show the net weight of the sample.
- Remove the whole container, the display will show a negative value, which is the weight of the container.
- Press the **[Tare/Zero]** to zero the reading and the display shows zero and the NET symbol will turn OFF.

4.1.2 Weighing

- After zeroing the reading place a sample weight onto the pan and the display will show the weight of sample.
- The capacity tracker bar will indicate the percentage of the sample on the pan against capacity of the balance. When the reading is stable, the display will show the stable symbol.
- Users can select different weighing units by pressing the [Unit] key. The reading will change according to the unit selected. Previous recorded accumulated readings will be cleared when a new unit is selected.
- Units available: g / ct / GN / N / dr / Lb / oZ / oZt / tl t / tl H / tl S /CUS. The unit “g” is always active; all other units can be selected to be active or inactive.



4.1.3 Percent Weighing

This is used to measure the percentage between the sample weight and a standard weight.

E.g. Put your standard weight onto the pan and press the [%] key, the display will show 100.0%.per. This would then be taken as the standard weight. Remove the standard weight and the reading goes to zero, the display will show 0.0%.

You now place your sample weight onto the pan; the display will show the percentage of this sample weight in relation to the standard 100% weight.

Press the [%] key again and the display will return to normal weighing mode. Note: If the standard weight is too small, the percentage result may be not accurate.

4.1.4 Counting mode

- Put a sample onto the pan and when the reading is stable, press the **[Smpl]** key, the display will show “SP 10 pcs” ;
- Press the **[Unit]** key to select sample values from 10, 20, 50, 100 and 200.
- Press the **[Smpl]** key again, the display will show the unit weight for 1 piece for 1 second and then show the quantity pcs.
- To go back to weighing mode, press the **[Smpl]** key.

4.1.5 Weighing accumulation

Accumulation of each weighing value can be done, two modes are available: manual accumulation and automatic accumulation.



4.1.6 Manual accumulation

- In manual accumulation mode, place a weight onto the pan, after the stable symbol shows press the **[Print]** key, the weight will then be accumulated. The display will show "1 ACC " for 1 second and then return to weighing mode,
- Remove the weight and the scale will show zero, then place another weight onto the pan and follow the same procedure to accumulate.

4.1.7 Automatic accumulation

In this mode, place the weight onto the pan, after the stable symbol shows the reading will be accumulated automatically. The display will show "ACC X" for 2 seconds and then return to weighing mode.

- Remove the weight and the scale will show zero. Then place another weight onto the pan and the balance will continue to accumulate automatically.

4.1.8 Accumulation check

- When the reading is zero, press the **[Print]** key, users can check the amount of accumulations and the total value. The display will show the amount of accumulations as "X ACC " for 1 second and then show the total value "XXX.XX g" for 1 second, following this the display will return to normal weighing mode.

4.1.9 Maximum accumulation value

- The maximum accumulation value is 999999. If the value exceeds 999999, the display will show FULL.
- In weighing mode, press the **[%]** key to clear accumulation records.



5 PARAMETER SETTINGS

Users can press the **[Unit]** key to view and change parameter settings when the scale is counting down from POWER UP.

The balance has 5 parameters that can be set by the user.

FUNCTION	SECTION	DESCRIPTION
UNIT F1	See section 5.1.1	Sets the units to be used g / ct / GN / N / dr / Lb / oZ / oZt / tl t / tl H / tl S /CUS.
EL F2	See section 5.1.2	Sets the backlight AUTO EL : backlight automatically turns on when weight is applied to the top pan OFF EL : backlight always off ON EL: backlight always on
Ser F3	See section 5.1.3	Sets the print parameters
OFF F4	See section 5.1.7	Sets the auto power-off parameter
SETUP F5	See section 5.5	User set up parameters
tECH F6	See section 5.6	Technical parameters setting mode / factory setting

5.1.1 Unit setting

You can enable and disable the weighing units available to the user when they press the **[Unit]** key as described in section 4.2.

- In “Unit F1” mode, press **[Tare/Zero]** to check the status of each weighing unit.
- Press the **[Unit]** key to change the state of units.
- If unit CUS is selected as “ON”, press **[Tare/Zero]** and the scale will require the conversion rate between CUS and g. Press **[%]** to select the digit and press **[Smpl]** to change the value. **[Print]** will to move decimal point. After the setting is made, press **[Tare/Zero]** to save changes.
- Press **[Print]** to exit unit mode.



Units and conversion rates

	unit	conversion	symbol
01	g	1.0	g
02	Carats	5.0	ct
03	Grains	15.432358	GN
04	Newtons	0.009808	N
05	Drams	0.5643834	Dr
06	Pounds	0.002205	Lb
07	Ounce	0.035274	OZ
08	Ounce Troy	0.03215075	OZt
09	Taels T.	0.0266667	TL.t
10	Taels Hk.	0.026717	TL.H
11	Taels S.	0.026455	TL.S
12	CUS	User setting	CUS

5.1.2 Backlight setting

The backlight may be enabled or disabled by the user. If the backlight is disabled, the battery life will be greater. The following settings are available:

- When the LCD shows “EL F2”, press **[Tare/Zero]**
- Three modes are available: always on, always off and automatic.
- **[Unit]** is used to change the setting; **[Tare/Zero]** enters the setting, and **[Print]** saves the setting.

AUTO EL	Sets the backlight to operate automatically when a weight is placed on the balance or a key is pressed.
OFF EL	Sets the backlight to be off.
ON EL	Sets the backlight to be on for full time.



5.1.3 Communication

When the display shows “SEr F3” press **[Tare/Zero]** to enter the communication settings.

The following options are available for setting the output and accumulation functions:

Mode	Print Feature	Accumulation
Prn 232	Data is sent whenever the [Print] key is pressed.	Manual accumulation when the [Print] key is pressed.
CON 232	Data is sent continuously.	Accumulation is disabled.
AUTO 232	The weighing results will be sent to the communication port automatically whenever a stable reading is present. The balance has to return to zero before another reading is sent via the interface.	Automatic accumulation when stable

Press the **[Unit]** key to change the setting. Press **[Tare]** to confirm and move to the next parameter.

5.1.4 Communication modes

- Press **[Unit]** to go through parameters:
- Auto : sending data automatically when the scale is stable,
- Prn: Press **[Print]** to send data when the scale is stable.
- CON : the balance will send out data continuously.
- Press **[Tare/Zero]** to save changes and enter baud rate setting.



5.1.5 Baud rate setting

- Press [Unit] to go through the settings,
- Four baud rates are available:
 - 1200bps、 2400bps、 4800bps、 9600bps
- Press [Tare/Zero] to change the setting and to go back to communication mode setting,
- Press [Print] to exit communication mode.

5.1.6 Format settings

- The scale will print either using a format that includes stability indications or one with only the weight. There are 2 settings that can work as follows:

FOR 1	Data format is with line headings and extra line feeds as shown in section 7
FOR 2	Data format is printed as weight or count only

5.1.7 Auto

- Users can select the standby time before the scale will power off automatically (when internal battery option is fitted).

power off
- When the display shows “OFF F4” press [Tare/Zero] to select time from 0m, 5m, 10m, 20m and 30m. When 0m is selected, the function of auto power off is turned off.
- [Unit] is to show settings between 0 and 30. [Print] is to save changes and exit this mode.



5.5 Set Up

Users can select various settings that may be suitable for certain applications.

- FIL controls the speed of response of the weighing, it can be set from 0-6, default is 3
- ZEO controls the zero tracking, it can be set from 0-6, default is 3
- ZTR controls the sensitivity, it can be set from 0-6, default is 4
- STA controls the speed of stability indication, it can be set from 0-6, default is 2

5.6 Technical parameters

- When the display shows “TECH F5” press [Tare/Zero] to enter the Technical parameter settings menu and then enter the dealer PIN. This is for dealers only.

6 SIMPLE CALIBRATION

Press [**Smpl**] and [**Print**] together whilst the display is counting down from POWER UP, the display will show "unload CAL."

Make sure the top pan is empty and when the stable symbol shows press [**Tare/Zero**] to enter calibration mode. The [**Unit**] key allows you to select a calibration weight value. See the table as below.

Press [**Tare/Zero**] to select the correct value

The display will show “LOAD WEI”. Place the weight onto the pan and press [**Tare/Zero**] when the stable symbol shows. If calibration is correct the display will show “PASS” and then go back to weighing mode.

If the weight placed on is more than 110% of the calibration weight value selected, the display will show “FAIL H”. If the weight placed on is less than 90% of calibration weight value selected, the display will show “FAIL L”.

Users should recalibrate the balance following the correct operation.+

Calibration weights:

Model	MCB500	MCB200
Weights (g)	200	100



7 COMMUNICATIONS

See parameters 5.3 Setting the Printing Parameters / Accumulation section for full information on settings.

The standard Interface parameters are:

RS-232 output of weighing data ASCII code 4800 Baud 8 data bits No Parity

Connection details are:

RS-232 Connector: 9 pin d-subminiature socket Pin 2 Output Pin 3 Input Pin 5 Signal Ground

Generally, a Null model cable is required for connection to a computer or printers.

Data Format for normal weighing operations, parts counting or recalling of totals from memory will all be different. All lines end with a carriage return and a line feed, (0dH and 0aH in ASCII).

Format 1 Output:

The lines will include a heading for each line then the value. A typical output when weighing is shown below. 3 lines of data are printed followed by 2 blank lines.

G S _ _ _ _ _ 1 2 3 . 4 5 _ g _ <cr> <lf>	19 ASCII Characters, GS for Gross Weight, NT for Net Weight
N o . _ _ _ _ _ _ _ 0 1 <cr> <lf>	16 Characters, Increments every time a weight is stored
T o t a l _ _ _ 1 2 3 . 4 5 _ g _ <cr> <lf>	19 Characters, The total weight stored in memory
<cr> <lf>	Includes 2 blank lines
<cr> <lf>	



When the scale is at zero the weight is not printed.

If the scale is set for continuous output, the weight only is printed followed by 2 blank lines. An example of continuous output is shown below.

```
G T , N T ± _ _ _ _ _ 1 2 3 . 4 5 _ g _ <cr> <lf>
<cr> <lf>
<cr> <lf>
```

Includes 2 blank lines

22 Characters, ST for stable/US for unstable followed by GS for Gross Weight/ NT for Net Weight and then a minus sign for negative weight, or a space for positive weight.

Format 2 Output:

The output will be the same value as is on the display. If in parts counting it will displayed as PCS, if in weighing it is only the weight.

An example output is:

```
± _ _ _ _ _ 1 2 3 . 4 5 _ g _ <cr> <lf>
```

Parts Counting example:

```
± _ _ _ _ _ 1 2 5 P C S <cr> <lf>
```

18 Characters, Begins with the sign, a minus sign for negative weight, or a space for positive weight.

For all examples if the weighing unit is one letter (i.e. grams=g) the 2nd of the units positions is a space before and after. If it is 2 letters long the 1st and second position is used with a space after the second letter, (i.e. 0.12345lb__) or if it is 3 letters long all 3 positons are used, (i.e 123.45dwt).



Input command format:

The scale can be controlled with the following commands. The commands must be sent in upper case letters, i.e. “T” not “t”.

T<cr><lf>	Tares the scale to display the net weight. This is the same as pressing [Tare] key.
Z<cr><lf>	Sets the zero point for all subsequent weighing. Display shows zero.
T5.345<cr><lf>	Would be same as entering a preset tare value of 5.345 from keypad
P<cr><lf>	Prints the results to a PC or printer using the optional RS-232 interface. It also adds the value to the accumulation memory if the accumulation function is not set to automatic.

8 ERROR MESSAGES

If an error message is shown, repeat the step that caused the message. If the error message is still shown then contact your dealer for support.

code	Description	reason	Solution
OVER err	A/D overload	There might be weight on the pan when the scale is turned on. Calibration fails. Load cell damaged	Remove weights Recalibrate
UNDER err	A/D low	Pan is not put on. Calibration fails Load cell damaged	Put on pan, restart the scale. Recalibrate
	Lack of power		Recharge the battery
FAIL	Calibration fails	Wrong calibration weight Users' calibration exceeds factory calibration by 5% Load cell damaged	Recalibrate with correct weight



Manufacturer's Declaration of Conformity

This product has been manufactured in accordance with the harmonised European standards, following the provisions of the below stated directives:

Electro Magnetic Compatibility Directive 2004/108/EC

Low Voltage Directive 2006/95/EC

FCC COMPLIANCE

This equipment has been tested and found to comply with the limits for a Class A digital device, pursuant to Part 15 of the FCC Rules. These limits are designed to provide reasonable protection against harmful interference when the equipment is operated in a commercial environment. The equipment generates, uses, and can radiate radio frequency energy and, if not installed and used in accordance with the instruction manual, may cause harmful interference to radio communications. Operation of this equipment in a residential area is likely to cause harmful interference in which case the user will be required to correct the interference at his own expense.

Shielded interconnect cables must be employed with this equipment to insure compliance with the pertinent RF emission limits governing this device.

Changes or modifications not expressly approved by the manufacturer could void the user's authority to operate the equipment.

WEEE COMPLIANCE



Sealed Lead Acid
Battery
Must be recycled
Properly

Any Electrical or Electronic Equipment (EEE) component or assembly of parts intended to be incorporated into EEE devices as defined by European Directive 2002/95/EEC must be recycled or disposed using techniques that do not introduce hazardous substances harmful to our health or the environment as listed in Directive 2002/95/EC or amending legislation. Battery disposal in landfill sites is more regulated since July 2002 by regulation 9 of the Landfill (England and Wales) Regulations 2002 and Hazardous Waste Regulations 2005. Battery recycling has become topical and the Waste Electrical and Electronic Equipment (WEEE) Regulations are set to impose targets for recycling.



Change log

Date of change	Change	Version
31-10-2019	New manual	001